

## MEMS VOA (BNC Interface)



### ■ Product Overview

This series of variable optical attenuators is based on Micro-Electro-Mechanical System (MEMS) technology and features fiber optic coupling design, enabling continuous voltage-controlled adjustment of optical power in single-mode fibers. The device supports DC voltage input for setting fixed attenuation values and is compatible with AC modulation signals up to 1 kHz. Built-in protection diodes effectively suppress input voltage transients, providing electrostatic discharge (ESD), overvoltage, and undervoltage protection to ensure reliable operation of the device.

### ■ Operating Guide

#### 1. Unpacking and Installation

Handle the device with care after unpacking. Both fiber pigtails exhibit bidirectional symmetry in optical performance and can serve as either the optical signal input or output port. In practical applications, due to the random nature of core alignment, it is recommended to test and select the connection end with lower insertion loss.

#### 2. Electrical Connection and Control

Connect an external voltage source via the BNC interface. Applying a control voltage of 0 to 5 V enables attenuation adjustment. Optical transmittance decreases monotonically with increasing control voltage (refer to the typical response curve). Please note that the minimum attenuation value is significantly affected by connector alignment accuracy, especially under short-wavelength and small-core conditions. To achieve optimal performance, it is recommended to fusion splice the device's fiber pigtail with the system fiber, which requires prior removal of the FC/APC connectors.

#### 3. Performance Optimization Tips

For short-wavelength applications, it is advisable to improve connection repeatability and stability through precise alignment or fusion splicing to ensure the attenuation performance meets design expectations.

## ▣ Product Features

**Precise Voltage Control:** Utilizes MEMS technology. Continuous and rapid attenuation adjustment of optical power in single-mode fibers can be achieved using 0-5 V DC or AC modulation voltages up to 1 kHz.

**Integrated Voltage Protection:** Built-in protection diodes provide electrostatic discharge (ESD), overvoltage, and undervoltage protection, enhancing device reliability and durability.

**Broad Spectrum Compatibility:** Offers six specific wavelength models, covering major bands from visible to near-infrared light, compatible with various laser sources.

**Low Return Loss:** Optical return loss greater than 30 dB, effectively reducing the impact of reflected light on the system.

**Flexible Connection and Optimization Solution:** Standard FC/APC connectors for convenient plug-and-play use. Fusion splicing is also recommended to minimize insertion loss and achieve optimal performance.

## ▣ Application Scope

**Fiber Optic Communication Systems:** Used for power management and equalization at the transmitter or receiver end.

**Laser and Optoelectronic Experiments:** Used in laboratories to adjust signal strength, simulate transmission loss, or protect sensitive detectors.

**Test and Measurement Systems:** Serves as a programmable attenuation unit in optical device testing platforms (e.g., testing optical receiver sensitivity).

**Sensing and Instrument Integration:** Integrated into fiber optic sensing systems or analytical instruments to achieve automated optical path adjustment and stable output.

 **Specifications**

Parameter	Unite	
Wavelength Range	nm	C band:1530~1570nm L band:1570~1610nm
Attenuation Type	--	Bright or Dark
Attenuation Range	dB	≥30
Insertion Loss	dB	≤0.7
Attenuation Resolution	dB	Continuous
Extinction Ratio (⊥)	dB	≥18
Wavelength Dependent Loss	dB	≤0.3@ 0dB , ≤1.5 @20dB
Temperature Dependent Loss (compare with RT)	dB	≤0.7@ 0dB , ≤1.0 @20dB
Return Loss	dB	≥45
Fiber Type	--	PM fiber
Response Time (10-90%optical power)	ms	≤3
Driving Voltage	V	6.5V or 15V
Driving Power	mW	≤2
Maximum Optical Power	mW	≤500
Operating Temperature	°C	-0~+70
Storage Temperature	°C	-40~+85

Notes: specified without connectors

Product Dimensions

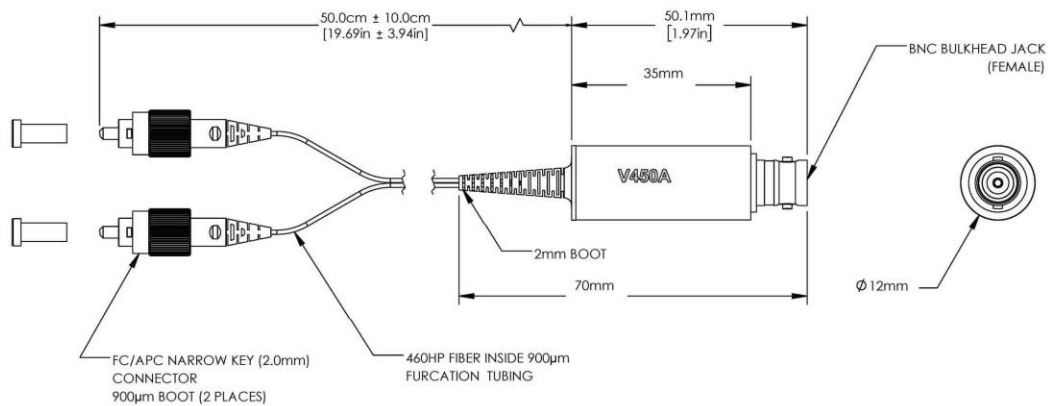
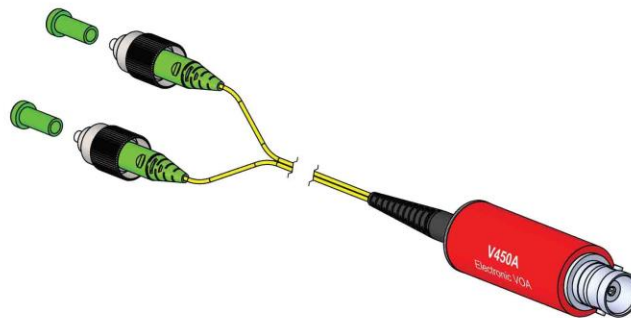

Ordering Information: A-B-C-D-E-F-G-H

	A	B	C	D	E	F	G	H
MVOA	wavelength	Att. Type	Drive Voltage	Fiber Type	Pigtail Length	Pigtail Type	Input	output
	1=850nm 2=1064nm 3=1310nm 4=1550nm X=Customized	B=Bright D=Dark	05=5V 15=15	1=SMF-28 2=HI 1060 3=MM50/125 4=MM60/125 X=Customized	05=0.5m 10=1.0m	B=Bare Fiber L=900um Loose Tube	0=None 1=FC/UPC 2=FC/APC 3=SC/UPC 4=SC/APC 5=LC/UPC 6=LC/APC	0=None 1=FC/UPC 2=FC/APC 3=SC/UPC 4=SC/APC 5=LC/UPC 6=LC/APC